

1986 - 1991

# HARDER

## ELECTRI - SPREAD<sup>®</sup> PICK-UP SANDERS

### Parts List

Series I

In the interest of simplicity, all models of the Harder "Electri-Spread" pickup sander use the same basic components. The 1 Yd. and smaller sanders use a short (66 inch) conveyor frame, while the 1 $\frac{3}{4}$  Yd. and larger sanders use a long (90 inch) conveyor frame.

Always reference the unit's serial number when procuring replacement parts. Since the optional stainless steel version of the Harder "Electri-Spread" pickup sander has proven far more popular than the standard mild steel painted version, all replacement parts orders will be filled with the stainless steel type (unless otherwise specified).

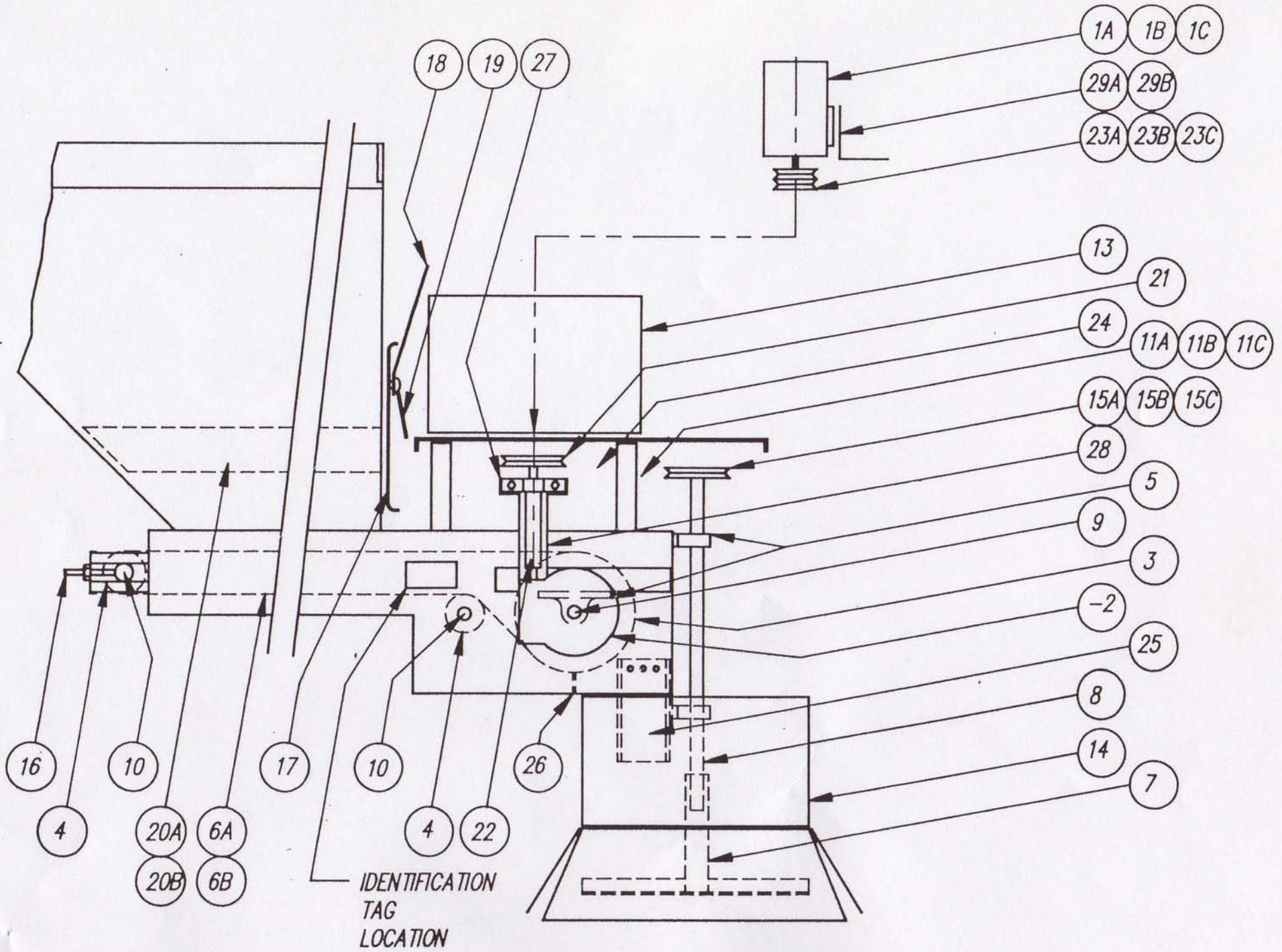

<u>PART N.</u>	<u>DESCRIPTION</u>	<u>QTY / MACH</u>	<u>PRICE</u>	<u>PART NO.</u>	<u>DESCRIPTION</u>	<u>QTY / MA</u>	<u>PRICE</u>
100-1A	12 V DC Electric Motor	1		100-15B	Spinner Pulley (Hyd. Mtr.)	1	
-1B	Hydraulic Motor	1		-15C	Spinner Pulley (Gas Motor)	1	
-1C	Gasoline Motor	1		-16	Take-up Roller Adjustment Rod	2	
-2	Gearbox	1		-17	Hopper Door	1	
-3	Drive Roll (Rubber lagged)	1		-18	Door Handle	1	
-4	Take-up/Snubbing Roll	1/1		-19	Door Handle Clamping Nut	1	
-5	1" Pillow Block (Ball Brg.)	4		-20A	Inverted "V" 1¾ Yd. & Larger	1	
-6A	139" Conveyor Belt for 1 Yd. & smaller (66" frame)	1		-20B	Inverted "V" 1 Yd. & Smaller	1	
-6B	187" Conveyor Belt for 1¾ Yd. & Larger (90" frame)	1		-21	Gearbox Pulley	1	
-7	Spinner (Please state if CW or CCW Rotation)	1	<i>SIDEMTD SHAF.T. UP - CCW TOP MTD SHAF.T. DN - CW</i>	-22	Gearbox Input Shaft Ext.	1	
-8	Spinner Shaft	1		-23A	Electric Motor Pulley	1	<i>Single or Dbl Pulley</i>
-9	Main Roll Drive Shaft	1		-23B	Hydraulic Motor Pulley	1	
-10	Take-up/Snubbing Roller Shaft	1/1		-23C	Gas Motor Pulley	1	
-11A	Spinner V-Belt (Electric Motor)	1		-24	Gearbox V-Belt	1	
-11B	Spinner V-Belt (Hydraulic Motor)	1		-25	Internal Chute	2	
-11C	Spinner V-Belt (Gas Motor)	1		-26	Belt Scraper	2	
-12	Electric Installation Kit (Not Shown)	1		-27	Input Shaft Support Bearing	1	
-13	Motor Housing & Baseplate	1		-28	Input Shaft Support Bracket	1	
-14	S/S Skirt with Flapper	1		-29A	Electric Motor Adapter	1	
-15A	Spinner Pulley (Electric Motor)	1		-29B	Hydraulic Motor Adapter	1	
				-30A	Hopper Screen, 1¾ Yd. & 3 Yd. (Not Shown)	1	
				-30B	Hopper Screen, 1 Yd. (Not Shown)	1	
				-30C	Hopper Screen, ½ Yd. (Not Shown)	1	



# Hub City

## WORM GEAR SPEED REDUCER PARTS LIST

## SERIES W300 MODEL W300

SHAFT MOUNTED

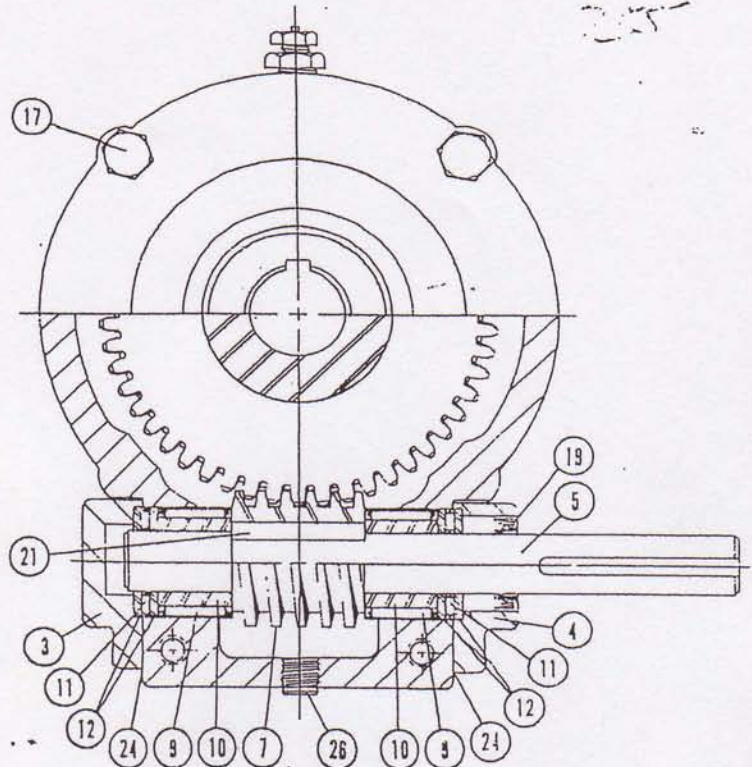
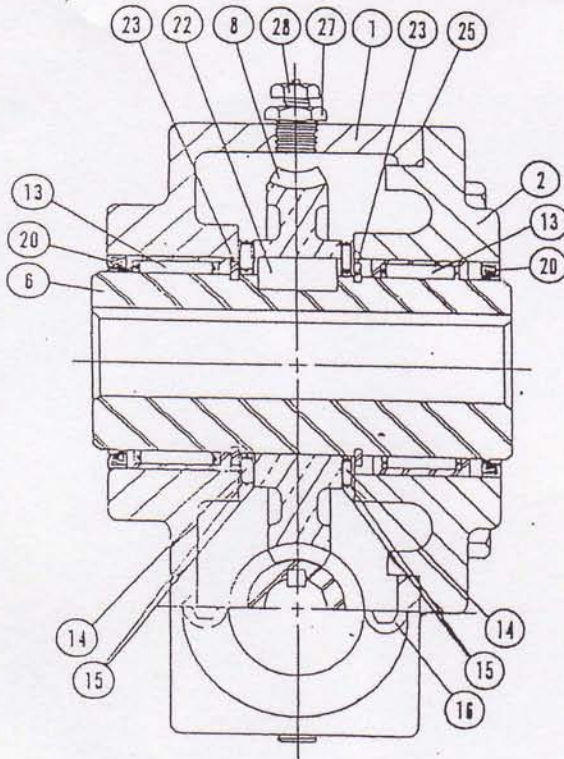

REF. NO.	PART NUMBER	DESCRIPTION	NO. REQ.	REF. NO.	PART NUMBER	DESCRIPTION	NO. REQ.
1	02-23-00263-300	Housing	1	7		Worm (Continued)	
2	02-23-00264-300	Cap, Open Output	1		02-23-01877-260	20:1 Ratio	
3	02-23-02233-300	Cap, Closed Input (none required on double input)	1		02-23-01883-260	40:1 Ratio	
4	02-23-01522-300	Cap, Open Input (double input requires 2)	1		02-23-01885-260	50:1 Ratio	
5		Shaft, Input	1	8		Gear, Worm	1
	02-23-01523-300	Style A and B (Single Extension)			02-23-01874-260	10:1 Ratio	
	02-23-01524-300	Style Double Input (Double Extension)			02-23-01878-260	20:1 Ratio	
6		Sleeve, Output	1		02-23-01884-260	40:1 Ratio	
	02-23-00268-300	1" Diameter Bore			02-23-01886-260	50:1 Ratio	
	02-23-00272-300	1 1/8" Diameter Bore		9	8-32-31-00-022	Bearing, Needle (J1412)	2
	02-23-00273-300	1 1/4" Diameter Bore		10	8-32-21-77-005	Race, Inner (IRA-10)	2
CAUTION — Hub City recommends that both the worm and worm gear be replaced to obtain maximum life from the repaired unit. Replacement of only one member will result in an unsatisfactory life.				11	8-32-32-17-002	Bearing, Thrust (NTA-1018)	2
7		Worm	1	12	8-32-32-77-013	Race, Thrust (TRA-1018)	4
	02-23-01873-260	10:1 Ratio		13	8-32-31-00-006	Bearing, Needle (Tor. B3216)	2
18	02-23-02087-300	KIT, REPAIR (INCLUDES ITEMS 19-28) THESE ITEMS ARE AVAILABLE IN REPAIR KIT ONLY — SEE ITEM NO. 29		14	8-32-32-17-001	Bearing, Thrust (NTA-3244)	2
19	8-74-21-25-043	Seal, Input Shaft (C/R 6141) (double input requires 2)	1	15	8-32-32-77-001	Race, Thrust (TRA-3244)	4
20	8-74-11-25-007	Seal, Output Sleeve (Garlock 76 x 7530)	2	16	8-47-11-44-008	Screw, Socket Hd. Cap (5/16 NC x 3/4)	4
21	8-47-17-05-030	Key, P & W (3/16 sq. x 1 1/8)	1	17	8-47-14-04-024	Screw, Hex Cap (5/16 NC x 1) GR5	4
22	8-47-17-05-054	Key, P & W (3/8 sq. x 1 1/8)	1	26	8-63-12-61-001	Plug, Pipe, Socket (1/4 NPT)	1
23	8-47-17-86-010	Ring, Retaining (Truarc 5108-200)	2	27	8-63-12-51-001	Bushing, Pipe (1/4 x 1/8)	1
24	02-23-00922-300	Gasket, Input Cap	10	28	8-63-12-71-001	Plug, Vented (1/2 NPT)	1
25	02-23-00923-300	Gasket, Output Cap	10	29	02-23-01608-300	KIT, REPAIR — Includes necessary parts to repair and convert the older Model W300. Reducers to be repaired with the kit have 02-20-02000-300 numbers. DO NOT order this kit to repair reducers with 02-20-06000-300 numbers.	

### PARTS ORDERING INFORMATION

When ordering replacement or spare parts, check metal tag on the gear case of your unit and furnish ALL of the following information:

GENERAL		SPECIFIC		PHONE OR WRITE	
1. Assembly Number	4. Style	6. Part Number	9. Your Name,	Your nearest Hub City Sales Office or Industrial Power Transmission Distributor listed in the Yellow Pages, or the Factory Sales Office.	
2. Model Number	5. Shipping Code	7. Complete Description	Address, Zip Code		
3. Ratio		8. Quantity Desired	and Phone Number		

NOTE — When more than one part number is listed after a reference number, examine each description carefully to determine which parts fit your need. Parts will be shipped "best way" unless specified.